

2.5A, 500KHz Synchronous Boost Converter

DESCRIPTION

The EUP2459 is a compact, high efficiency, fixed frequency, synchronous step-up converter. The 500KHz switching frequency allows for smaller external components producing a compact solution for a wide range of load currents.

High efficiency is accomplished by integrating the low resistance N-Channel Boost switch and synchronous P-Channel switch. All compensation and protection circuitry are integrated to minimize external components. The 500KHz high switching frequency allows smaller inductor and output capacitor, making the EUP2459 ideally suited for small battery-powered applications and saves PCB space. During shutdown, true load disconnect between battery and load prevent current flow from V_{IN} to V_{OUT} , as well as reverse flow from V_{OUT} to V_{IN} , which will extend the battery life greatly.

The EUP2459 contains thermal shutdown function and cycle-by-cycle current limit to protect the device in the event of an output short-circuit condition. Built-in soft-start circuitry prevents excessive inrush current during start-up.

The EUP2459 is available in a Pb-free, SOT23-5 package.

FEATURES

- V_{IN} Range: 2.5V to 5.0V
- Up to 1A Regulated Output Current
- High Efficiency up to 95%
- Internal Power MOSFET and Synchronous Rectifier
- 500KHz Fixed Switching Frequency
- 0.1 Ω NCH Switch
- Tiny External Components
- Output Short to GND protection
- Current Mode with Internal Compensation
- True Load Disconnect
- <1 μ A Shutdown Current
- Available in SOT23-5 Package
- RoHS Compliant and 100% Lead(Pb)-Free Halogen-Free

APPLICATIONS

- GPS PND
- Single Cell Li-Ion to 5V Converter
- PDAs, Portable Media Players
- Handheld Instruments

Typical Application Circuit

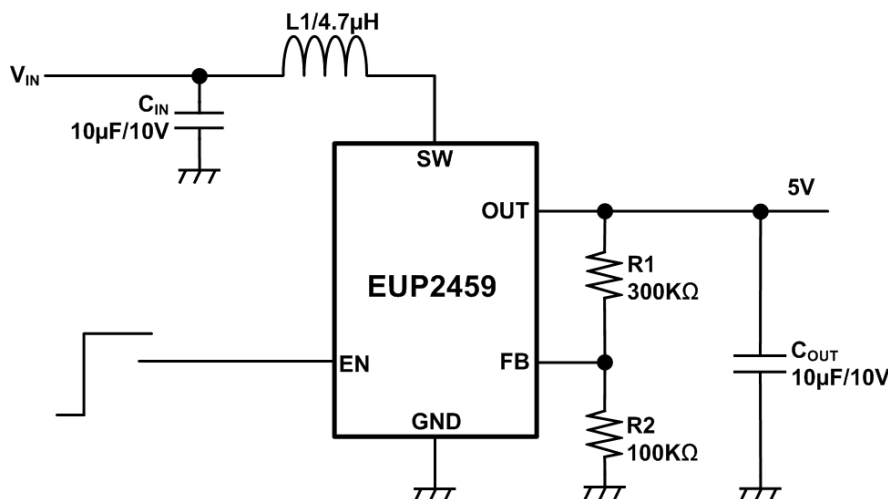

Figure1. Typical Application Circuit