

2.5-W/CH Stereo Filter-less Class-D Audio Power Amplifier with Auto-Recovery

DESCRIPTION

The EUA2012A is a high efficiency, 2.5W/channel stereo class-D audio power amplifier. A low noise, filterless PWM architecture eliminates the output filter, requiring only two external components for operation.

Operating from a single 5V supply, EUA2012A is capable of delivering 2.5W/ channel of continuous output power to a 4Ω load with 10% THD+N.

The EUA2012A features independent shutdown controls for each channel. The gain can be selected to 6, 12, 18, or 24 dB utilizing the G0 and G1 gain select pins. High PSRR and differential architecture provide increased immunity to noise and RF rectification.

The EUA2012A is available in space-saving WCSP, TQFN and TSSOP packages, is an idea choice for mobile phones and other portable communication devices.

FEATURES

- Low EMI Emission
- Output Power By TQFN Package
 - 2.5W/Ch Into 4Ω at 5V
 - 1.6W/Ch Into 8Ω at 5V
 - 800mW/Ch Into 8Ω at 3.6V
- Wide Supply Voltage: 2.5V to 5.5V
- Independent Shutdown Control for Each Channel
- Selectable Gain of 6,12,18 and 24 dB
- High PSRR :63dB at 217Hz
- Fast 34ms Startup Time
- Low 5mA Quiescent Current at 3.6V Supply and 1.5μA Shutdown Current
- Short-Circuit Auto-Recovery and Thermal Protection
- Space Saving Packages
 - 4mm×4mm TQFN-20 package
 - 2mm×2mm WCSP-16 package
 - TSSOP-20 package
- RoHS Compliant and 100% Lead(Pb)-Free, Halogen-Free

APPLICATIONS

- Wireless or Cellular Handsets and PDAs
- Portable Audios
- Notebook PC

Typical Application Circuit

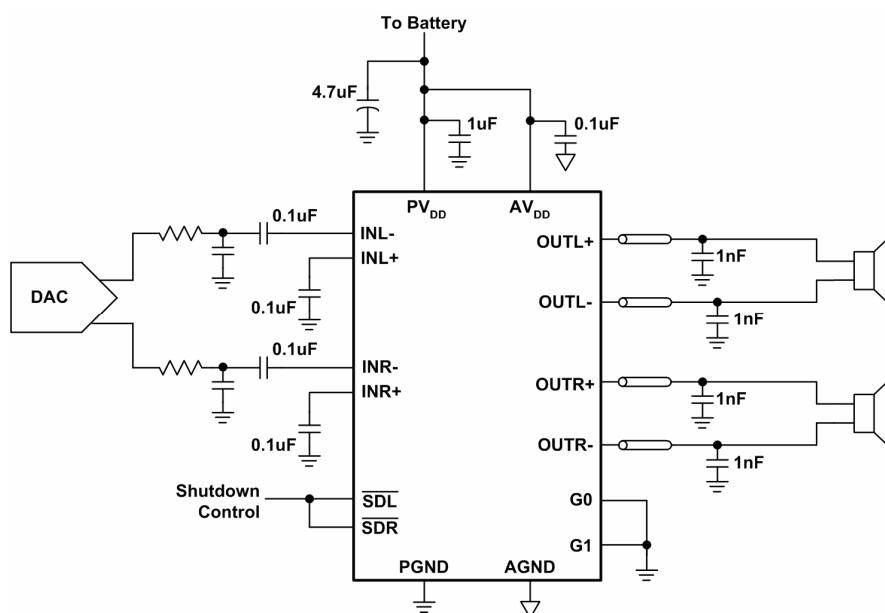

Figure1.