

3.3W Mono Class-D Audio Power Amplifier with Non-Clip and Power Limit

DESCRIPTION

The EUA2068A is a high efficiency, 3.3W mono class-D audio power amplifier with Non-Clip and Power Limit. A low noise, filterless PWM architecture eliminates the output filter, reducing external component count, system cost, and simplifying design.

EUA2068A having power limit interlock non-clip function, controls gain automatically and prevents output signals from being clipped at the supply voltage. In addition, this power limit function permits the maximum output to be arbitrarily specified to 100mW to 1000mW according to a speaker to use.

Furthermore, EUA2068A also integrate overcurrent and overtemperature protection functions, DC output protection function, under-voltage malfunction prevention function, as well as EMI noise and the pop noise reduction functions.

The EUA2068A is available in space-saving WCSP package.

FEATURES

- Unique Modulation Scheme Reduces EMI Emissions
- Unique Non-Clip function , Variable NCNA, NCNB,NCNOFF mode Select
- 3.3W 4-Ω Load at $V_{DD}=5V$, THD+N <10%
- Low Quiescent Current, $I_{DD}=4mA @5V$
- 2.5V to 5.5V Wide Supply Voltage
- Overcurrent Protection Function (OCP)
- Overtemperature Protection Function (OTP)
- DC Output Protection Function (DCOP)
- Under-voltage Malfunction Prevention Function (UVL)
- Short Circuit Auto-Recovery
- Power Limit Function
- 1.5mm × 1.5mm Wafer Chip Scale Package (WCSP)
- RoHS Compliant and 100% Lead(Pb)-Free Halogen-Free

APPLICATIONS

- Smart Phones/Cellular Phones
- Portable Multimedia Players

Typical Application Circuit

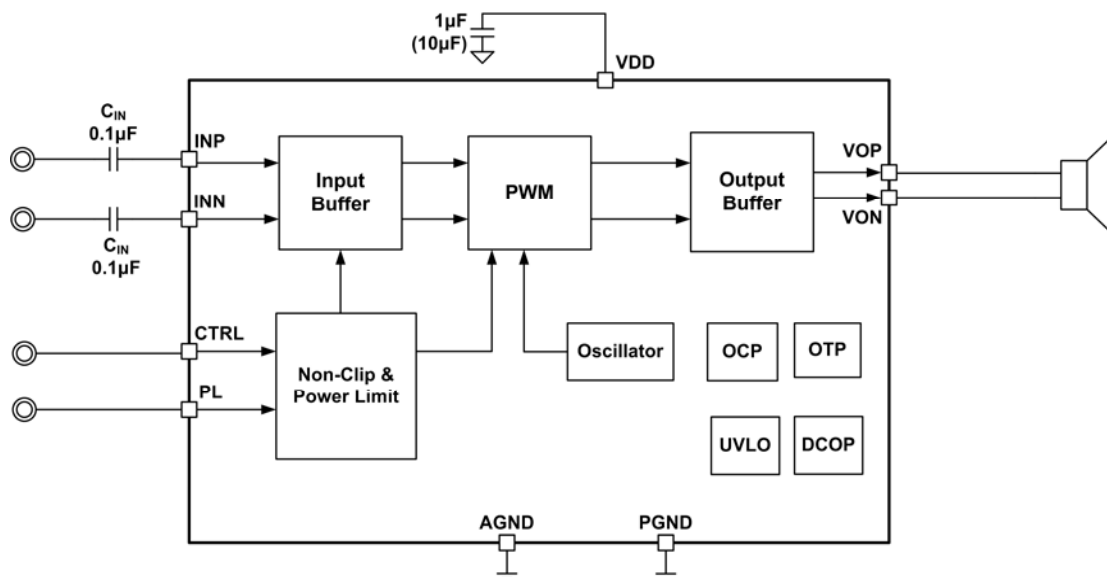

Figure1.